

Tuesday 24 May 2016 – Morning

AS GCE PHYSICS A

G481/01 Mechanics

Candidates answer on the Question Paper.

OCR supplied materials:

- Data, Formulae and Relationships Booklet (sent with general stationery)

Other materials required:

- Electronic calculator
- Protractor
- Ruler (cm/mm)

Duration: 1 hour



Candidate forename		Candidate surname	
--------------------	--	-------------------	--

Centre number						Candidate number				
---------------	--	--	--	--	--	------------------	--	--	--	--

INSTRUCTIONS TO CANDIDATES

- Write your name, centre number and candidate number in the boxes above. Please write clearly and in capital letters.
- Use black ink. HB pencil may be used for graphs and diagrams only.
- Answer **all** the questions.
- Read each question carefully. Make sure you know what you have to do before starting your answer.
- Write your answer to each question in the space provided. If additional space is required, you should use the lined page at the end of this booklet. The question number(s) must be clearly shown.
- Do **not** write in the bar codes.

INFORMATION FOR CANDIDATES

- The number of marks is given in brackets [] at the end of each question or part question.
- The total number of marks for this paper is **60**.
- You may use an electronic calculator.
- You are advised to show all the steps in any calculations.



Where you see this icon you will be awarded marks for the quality of written communication in your answer.

This means for example you should:

- ensure that text is legible and that spelling, punctuation and grammar are accurate so that meaning is clear;
 - organise information clearly and coherently, using specialist vocabulary when appropriate.
- This document consists of **16** pages. Any blank pages are indicated.

Answer **all** the questions.

1 (a) Define *acceleration*.

.....
 [1]

(b) Explain why acceleration is a vector quantity.



In your answer, you should use appropriate technical terms, spelled correctly.

.....
 [1]

(c) Fig. 1.1 shows the graph of velocity v against time t for a moving object.



Fig. 1.1

(i) Describe the motion of the object from

1 $t = 0$ to $t = 2$ s

.....
 [1]

2 $t = 2$ s to $t = 7$ s.

.....
 [1]

(ii) Explain how Fig. 1.1 shows that the distance travelled by the object from $t = 0$ to $t = 2$ s is **shorter** than the distance travelled from $t = 2$ s to $t = 7$ s.

.....

 [1]

3

- (d)** The ventricle is one of two chambers in the heart that collects and expels blood. The left ventricle of the heart expels blood around the body. It accelerates blood from rest to a velocity of 0.26 m s^{-1} . The distance travelled by the blood during this acceleration is 0.020 m .

Assuming that the blood is accelerated uniformly, calculate the time taken for this acceleration.

time = s [2]

Question 2 begins on page 4

- 2 (a) Aristotle and Galileo had different ideas about the way in which objects fall to the ground. Compare these ideas.

.....

.....

.....

.....

.....

.....

..... [2]

- (b) Fig. 2.1 shows the graph of velocity against time for a parachutist falling vertically through the air. The initial vertical velocity is zero.

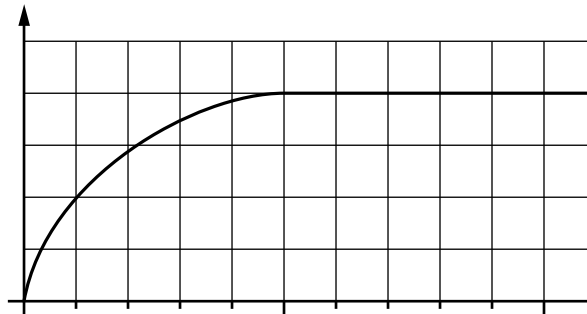

Fig. 2.1

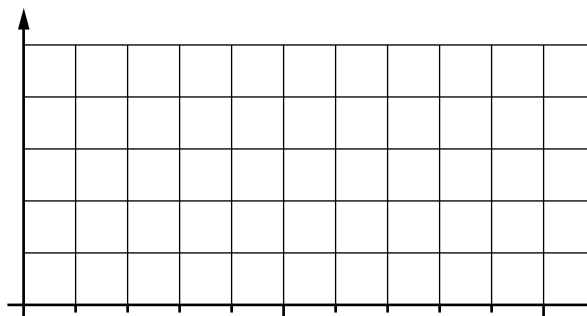

Fig. 2.2

- (i) State **two** factors that affect the magnitude of the drag force on the parachutist.

.....

..... [1]

- (ii) State and explain the magnitude of the acceleration of the parachutist at the start of the fall.

.....
.....
.....
..... [2]

- (iii) On Fig. 2.2 sketch a graph to show the variation of the size of the **resultant** force F acting on the parachutist with time t . [2]

- (iv) The total mass of the parachutist is 80kg. Calculate the drag force acting on the parachutist at an acceleration of 3.0 ms^{-2} .

drag force = N [3]

Question 3 begins on page 6

- 3 Fig. 3.1 shows a stunt rider on a powerful motorbike at **X** at the top of a ramp.

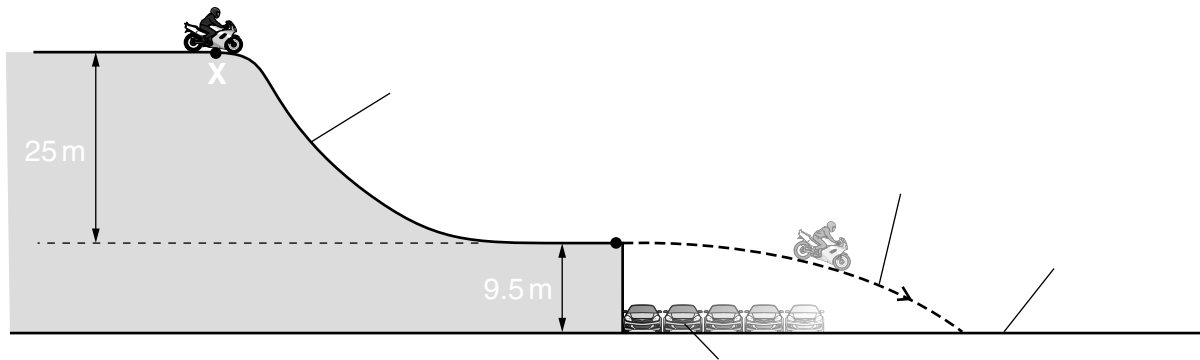

Fig. 3.1

The total mass of motorbike and rider is 190 kg. The height difference between the top and the bottom of the ramp is 25 m. The rider uses the engine to accelerate down the ramp. He leaves the end of the horizontal section of the ramp at **Y** with a speed of 30 m s^{-1} .

- (a) Calculate the loss of gravitational potential energy E_p of the rider and motorbike from **X** to **Y**.

$$E_p = \dots\dots\dots \text{ J [1]}$$

- (b) Calculate the kinetic energy E_k of the rider and motorbike at **Y**.

$$E_k = \dots\dots\dots \text{ J [1]}$$

- (c) Explain why your answer to (b) is **greater** than your answer to (a).

.....

 [1]

- (d) The total distance travelled by the motorbike from **X** to **Y** along the ramp is 120 m. Calculate the average accelerating force that the motorbike engine provides along the ramp.

force = N [2]

- (e) The end of the ramp at **Y** is at a height of 9.5 m above the ground. The motorbike travels through the air after leaving the ramp and flies over a number of cars lined up side by side. Assume air resistance has negligible effect on the motion of the rider and motorbike.

- (i) Show that the time taken for the motorbike to travel from **Y** to the ground is 1.4 s.

[2]

- (ii) Each of the cars has a width of 1.8 m. Estimate the number of cars the motorbike can clear.

number = [2]

4 Fig. 4.1 shows a cyclist.

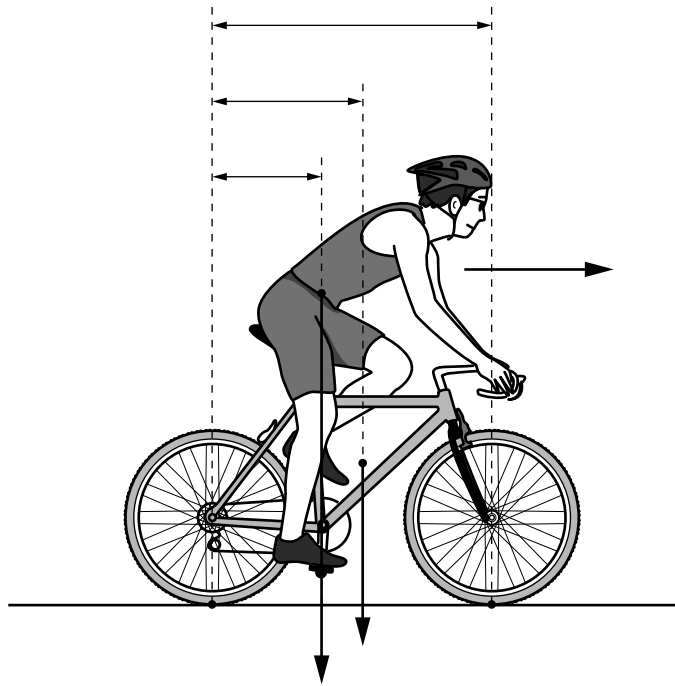

Fig. 4.1

The bicycle tyres are in contact with the road at **X** and **Y**. The cyclist is travelling at **constant** velocity on a level road. The weight of the bicycle is 180 N and the weight of the cyclist is 720 N.

(a) State the magnitude of the resultant force acting on the cyclist. Explain your answer.

.....

 [2]

(b) Define *moment of a force*.



In your answer, you should use appropriate technical terms, spelled correctly.

.....

 [1]

(c) Explain why the two vertical forces acting on the tyres at **X** and **Y** do not form a couple.

.....

 [1]

(d) Take moments about **X** to determine the size of the vertical force F acting **on** the tyre at **Y**.

$F = \dots\dots\dots$ N [3]

(e) The cyclist leans further forward. How does this affect the force on the tyre at **X**? Explain your answer.

.....

.....

.....

.....

..... [2]

Question 5 begins on page 10

5 (a) An airbag is an important safety feature in a car. During a collision, the driver's airbag is triggered by an accelerometer. The airbag inflates in less than 40ms. The airbag has holes and starts to deflate after about 0.3s.

(i) Suggest what might happen to the driver in a collision if the airbag did not have holes.

.....
 [1]

(ii) Explain how an airbag reduces the impact force on the driver.

.....

 [3]

(b) The table below shows how the braking distance x for a car depends on its initial speed u .

u/ms^{-1}	5.0	10	20	40
x/m	2.0	8.0	32	128

(i) State the relationship between x and u .

.....
 [1]

(ii) The reaction time of a driver is 0.60s. Calculate the **stopping distance** of the car when u is 30ms^{-1} .

distance = m [3]

- (c) Many cars are fitted with GPS receivers. Fig. 5.1 illustrates the technique of trilateration which is used by a GPS receiver to determine the location of a car on the Earth's surface.

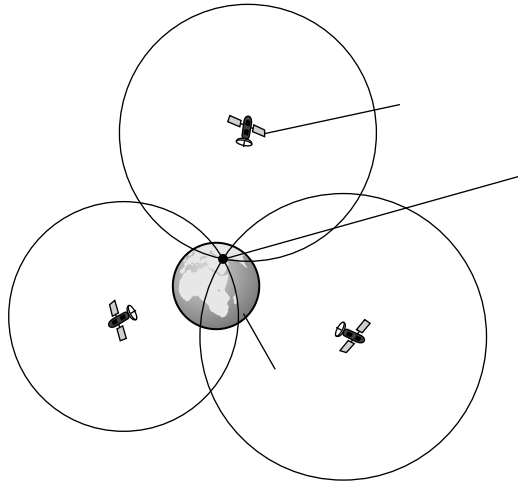

Fig. 5.1

- (i) Explain what the circle around each satellite in Fig. 5.1 represents.

.....
..... [1]

- (ii) Explain how a GPS receiver determines the distance between the car and a satellite.

.....
.....
.....
..... [2]

6 (a) (i) Define the *force constant* of a spring.

.....
 [1]

(ii) Fig. 6.1 shows a load supported by two identical springs arranged in parallel.

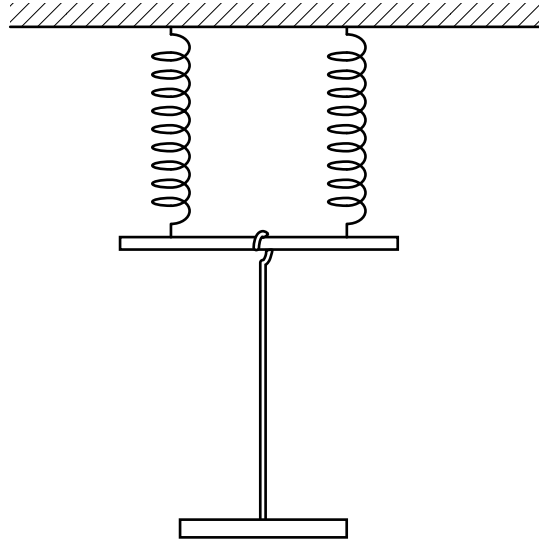

Fig. 6.1

Explain why the force constant of the parallel arrangement of springs is twice the force constant of one spring.

.....

 [1]

(c) Fig. 6.3 shows the graph of stress against strain for a wire made from a ductile material.

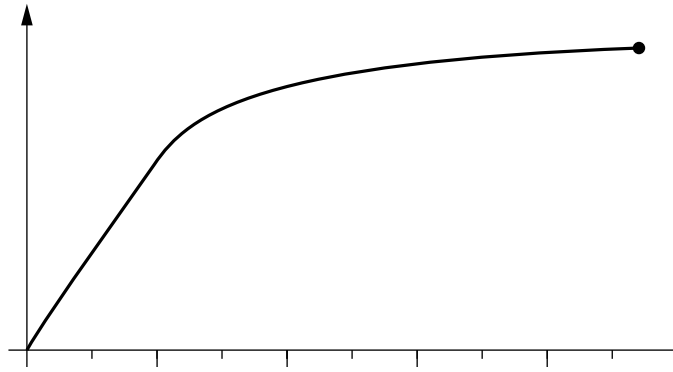

Fig. 6.3

(i) Describe the behaviour of the wire when the strain is less than 0.05%.

.....

 [1]

(ii) The wire is used to support a heavy load. The strain in the wire is 0.3%. Describe what happens to the wire when the load is removed.

.....

 [1]

(iii) A student suggests that the ratio of stress to strain at point **A** is equal to the Young modulus of the material. Explain whether or not this suggestion is correct.

.....

 [1]

- 7 A crane is used to lift a shipping container. The container has a mass of 2.8×10^4 kg and is lifted by **four** identical steel cables attached to the container as shown in Fig. 7.1.

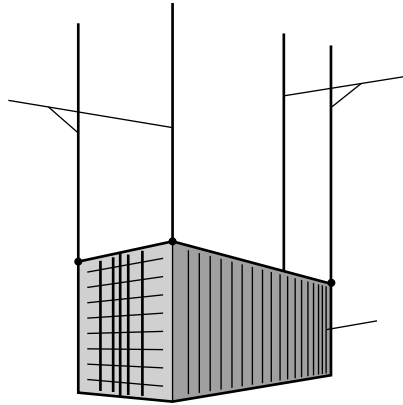

Fig. 7.1

Each cable has length 32 m and cross-sectional area 4.5×10^{-4} m². The container is lifted vertically at a **constant velocity**. The Young modulus of steel is 2.1×10^{11} Pa.

- (a) Calculate the extension in mm of each cable.

extension = mm [4]

- (b) The container is suddenly accelerated upwards. Explain the effect, if any, on the extension of the cables.

.....

.....

.....

..... [2]

END OF QUESTION PAPER

ADDITIONAL ANSWER SPACE

If additional answer space is required, you should use the following lined page. The question number(s) must be clearly shown in the margin.

A large rectangular area with a vertical solid line on the left side and horizontal dotted lines across the rest of the page, providing space for writing answers.



Copyright Information

OCR is committed to seeking permission to reproduce all third-party content that it uses in its assessment materials. OCR has attempted to identify and contact all copyright holders whose work is used in this paper. To avoid the issue of disclosure of answer-related information to candidates, all copyright acknowledgements are reproduced in the OCR Copyright Acknowledgements Booklet. This is produced for each series of examinations and is freely available to download from our public website (www.ocr.org.uk) after the live examination series.

If OCR has unwittingly failed to correctly acknowledge or clear any third-party content in this assessment material, OCR will be happy to correct its mistake at the earliest possible opportunity.

For queries or further information please contact the Copyright Team, First Floor, 9 Hills Road, Cambridge CB2 1GE.

OCR is part of the Cambridge Assessment Group; Cambridge Assessment is the brand name of University of Cambridge Local Examinations Syndicate (UCLES), which is itself a department of the University of Cambridge.